

Quality -based observations and viewpoints on sustainability and supply chain management



LAATUKESKUS
EXCELLENCE FINLAND

© Pekka O. Einistö, 2007

Sustainability?

Sustainability - what it is?



LAATUKESKUS
EXCELLENCE FINLAND

Pekka O. Einistö, 2007

Sustainability?

Sustainability - what it is?

What it especially is *not*?



Pekka O. Einistö, 2007

Sustainability?

Sustainability - what it is?

What it especially is *not*?

What is Un-sustainability?



Pekka O. Einistö, 2007

Un-sustainability?

Over-utilizing resources in the short term.

Un-sustainability?

Over-utilizing resources in the short term.

We do not (supposedly) do that?

Un-sustainability?

Over-utilizing resources in the short term.

We do not (supposedly) do that?

...or do we?



Pekka O. Einistö, 2007

Waste in quality movement

**Waste in quality thinking
is something unnecessarily
used or done in order to achieve
the desired outcome.**



Pekka O. Einistö, 2007

Waste in quality movement

**Poor quality is wasting
resources for no purpose.**



Pekka O. Einistö, 2007

Waste in quality movement

**Poor quality is wasting
resources for no purpose.**

Poor quality equals un-sustainability.



Pekka O. Einistö, 2007

Waste in quality movement

**Poor quality is wasting
resources for no purpose.**

Poor quality equals un-sustainability.

Good quality equals sustainability.



LAATUKESKUS
EXCELLENCE FINLAND

Pekka O. Einistö, 2007

Sustainability and quality

Do It Right First Time

- Philip Crosby



LAATUKESKUS
EXCELLENCE FINLAND

Pekka O. Einistö, 2007

Seven wastes of quality movement

1. Unnecessary waiting

Seven wastes of quality movement

1. Unnecessary waiting

2. Unnecessary transportation of goods

Seven wastes of quality movement

- 1. Unnecessary waiting**
- 2. Unnecessary transportation of goods**
- 3. Unsuitable processing or non-optimized work methods**

Seven wastes of quality movement

- 1. Unnecessary waiting**
- 2. Unnecessary transportation of goods**
- 3. Unsuitable processing or non-optimized work methods**
- 4. Unnecessary motion**

Seven wastes of quality movement

1. Unnecessary waiting
2. Unnecessary transportation of goods
3. Unsuitable processing or non-optimized work methods
4. Unnecessary motion
5. Poor quality or quality defects

Seven wastes of quality movement

1. Unnecessary waiting
2. Unnecessary transportation of goods
3. Unsuitable processing or non-optimized work methods
4. Unnecessary motion
5. Poor quality or quality defects
6. Unnecessary, “just-in-case” or hidden inventories

Seven wastes of quality movement

- 1. Unnecessary waiting**
- 2. Unnecessary transportation of goods**
- 3. Unsuitable processing or non-optimized work methods**
- 4. Unnecessary motion**
- 5. Poor quality or quality defects**
- 6. Unnecessary, “just-in-case” or hidden inventories**
- 7. Overproduction – production to stock, in case somebody might need it**



LAATUKESKUS
EXCELLENCE FINLAND

Pekka O. Einistö, 2007

Sustainability in business

Sustainability and respect of environment are hallmarks of good quality.



LAATUKESKUS
EXCELLENCE FINLAND

Pekka O. Einistö, 2007

Sustainability in business

Sustainability and respect of environment are hallmarks of good quality.

Poor quality always results in defects, decay, obsolescence, repairing, rework or lost time (by somebody, somewhere).



Pekka O. Einistö, 2007

Sustainability in business

Sustainability and respect of environment are hallmarks of good quality.

Poor quality always results in defects, decay, obsolescence, repairing, rework or lost time (by somebody, somewhere).

Good quality also means higher profits.



Pekka O. Einistö, 2007

Sustainability in supplier networks

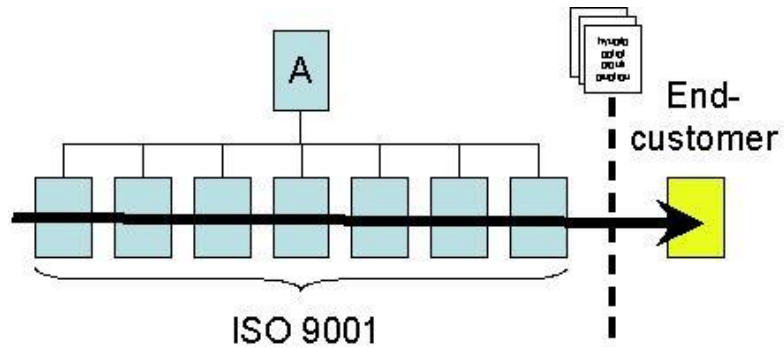

Sustainability in supplier networks

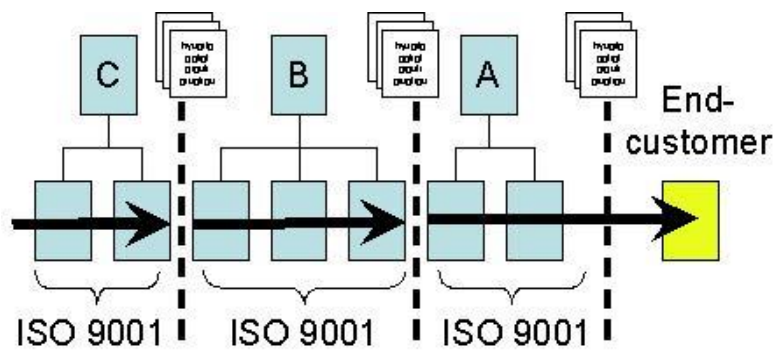

Sustainability in supplier networks

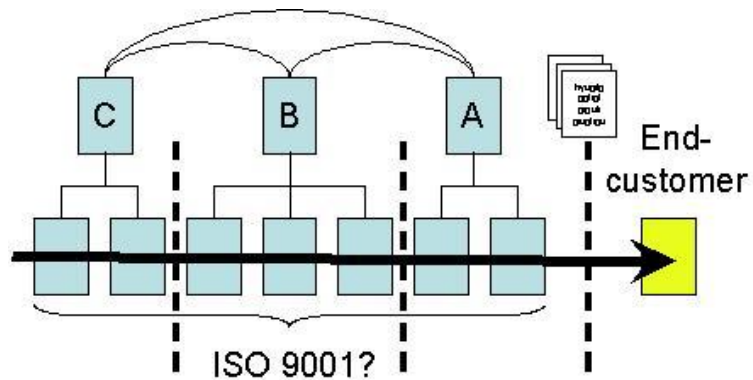

Sustainability?

**Sustainability is good quality:
whatever we do we should do it
as well as possible,
with minimum wastes resources
and right at first time.**

Sustainability?

**Sustainability is good quality:
whatever we do we should do it
as well as possible,
with minimum wastes resources
and right at first time.**

**In a value – or supplier – chain
we need to consider the quality of
the whole chain in order to promote
sustainability.**



Pekka O. Einistö, 2007

But do we?

Think about sustainability?



Pekka O. Einistö, 2007

But do we?

Think about sustainability?

And do we...



LAATUKESKUS
EXCELLENCE FINLAND

Pekka O. Einistö, 2007

But do we?

Think about sustainability?

And do we...

think about good quality?



LAATUKESKUS
EXCELLENCE FINLAND

Pekka O. Einistö, 2007

Thank you!

Laatukeskus promotes quality,
excellence and competitiveness
at finnish organizations
or companies operating inFinland



LAATUKESKUS
EXCELLENCE FINLAND

© Pekka O. Einistö, 2007